

6 PANEL MOLDED DOORS

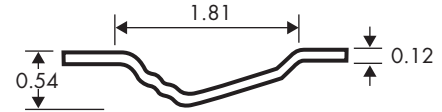

TEXTURED 8'0" BEAD AND COVE



Bead and Cove profile

HOLLOW CORE DOOR

- 1-3/8" and 1-3/4" hollow core
- Fingerjoint or Fiberwood stiles
- Wood rails available

SOLID CORE DOOR

- 1-3/8" and 1-3/4" solid core
- Gives solid feel with sound reduction
- All wood construction
- Available in particle board core

Sizes Available

Dimensions	Availability	Panels
1'0" x 8'0"	X	3
1'2" x 8'0"	X	3
1'3" x 8'0"	X	3
1'4" x 8'0"	√	3
1'6" x 8'0"	√	3
1'8" x 8'0"	√	3
2'0" x 8'0"	√	6
2'2" x 8'0"	X	6
2'4" x 8'0"	√	6
2'6" x 8'0"	√	6
2'8" x 8'0"	√	6
2'10" x 8'0"	√	6
3'0" x 8'0"	√	6

NOTE: Items designated with an X are cut from larger size skins.
Items designated with a √ are available for order. NA for Not Available.

6 PANEL MOLDED DOORS

TEXTURED 8'0" B/C



Standard Dimensions

DOOR SKIN DIMENSIONS*

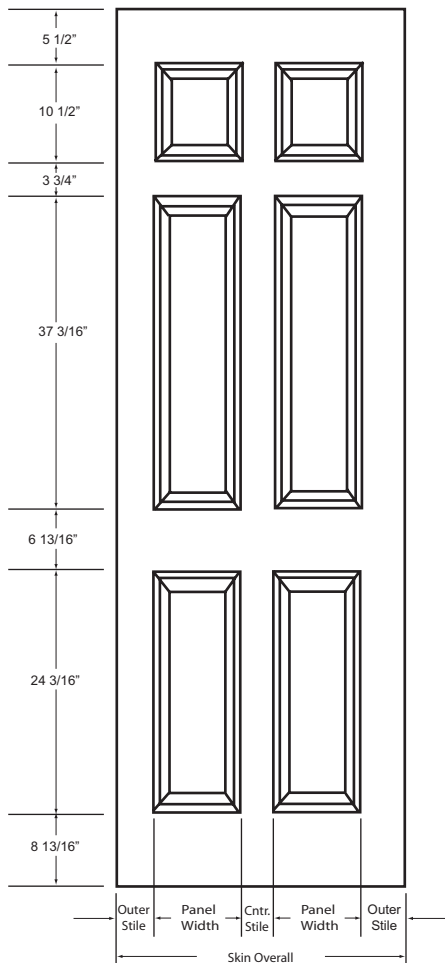

HOLLOW CORE CONSTRUCTION

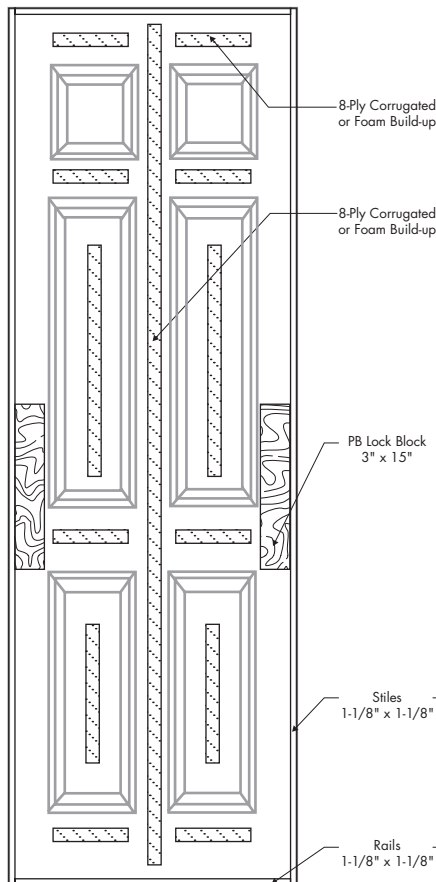

SOLID CORE CONSTRUCTION

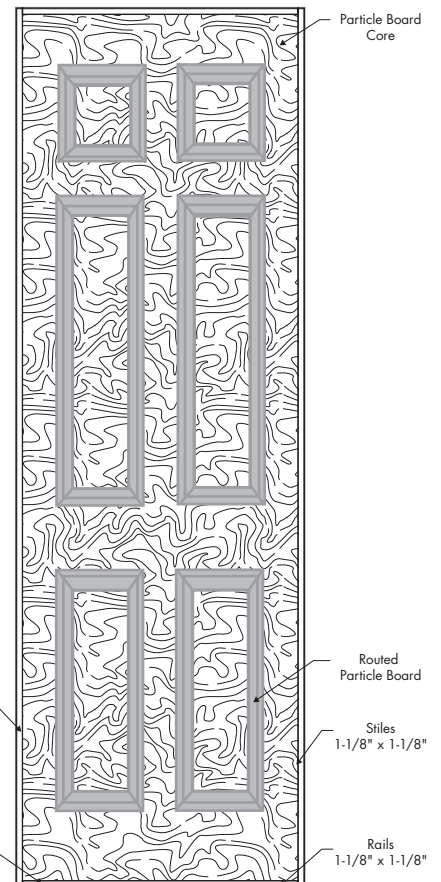

Smooth skin faces are paint grade only.
 All measurements are approximate.
 All door facings are nominal 1/8" thick.
 Type 2 glue bond standard.

*Measurements are approximate and before any required trim or adjustments for customer specifications

Skin Size	Skin Overall	Panel Width	Center Stile	Outer Stile
1'0" x 8'0"	1'0-3/8"	5-15/16"	NA	3-7/32"
1'2" x 8'0"	1'2-3/8"	7-15/16"	NA	3-7/32"
1'3" x 8'0"	1'3-3/8"	8-15/16"	NA	3-7/32"
1'4" x 8'0"	1'4-3/8"	9-15/16"	NA	3-7/32"
1'6" x 8'0"	1'6-3/8"	11-15/16"	NA	3-7/32"
1'8" x 8'0"	1'8-3/8"	11-15/16"	NA	4-7/32"
2'0" x 8'0"	2'0-3/8"	5-15/16"	3-7/8"	4-5/16"

Skin Size	Skin Overall	Panel Width	Center Stile	Outer Stile
2'2" x 8'0"	2'2-3/8"	5-15/16"	3-7/8"	5-5/16"
2'4" x 8'0"	2'4-3/8"	7-15/16"	3-7/8"	4-5/16"
2'6" x 8'0"	2'6-3/8"	8-15/16"	3-7/8"	4-5/16"
2'8" x 8'0"	2'8-3/8"	9-15/16"	3-7/8"	4-5/16"
2'10" x 8'0"	2'10-3/8"	9-15/16"	3-7/8"	5-5/16"
3'0" x 8'0"	3'0-3/8"	11-15/16"	3-7/8"	4-5/16"

Note: A standard 2-1/8" bore diameter will require a minimum stile measurement of 3-11/16" to allow for a 2-3/8" backset. A standard 2-1/8" bore diameter will require a minimum stile measurement of 4-1/16" to allow for a 2-3/4" backset.