

2 PANEL ROUNDTOP MOLDED DOORS

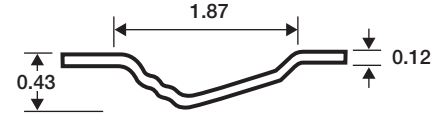

SMOOTH

7'0" BEAD AND COVE



Bead and Cove profile

HOLLOW CORE DOOR

- 1-3/8" and 1-3/4" hollow core
- Fingerjoint or Fiberwood stiles
- Wood rails available

SOLID CORE DOOR

- 1-3/8" and 1-3/4" solid core
- Gives solid feel with sound reduction
- All wood construction
- Available in particle board core

Sizes Available

Dimensions	Availability	Panels
1'0" x 7'0"	X	2
1'2" x 7'0"	X	2
1'3" x 7'0"	X	2
1'4" x 7'0"	√	2
1'6" x 7'0"	√	2
1'8" x 7'0"	√	2
2'0" x 7'0"	√	2
2'2" x 7'0"	X	2
2'4" x 7'0"	√	2
2'6" x 7'0"	√	2
2'8" x 7'0"	√	2
2'10" x 7'0"	√	2
3'0" x 7'0"	√	2

NOTE: Items designated with an X are cut from larger size skins.
Items designated with a √ are available for order. NA for Not Available.

2 PANEL ROUNDTOP MOLDED DOORS

SMOOTH 7'0" B/C



Standard Dimensions

DOOR SKIN DIMENSIONS*

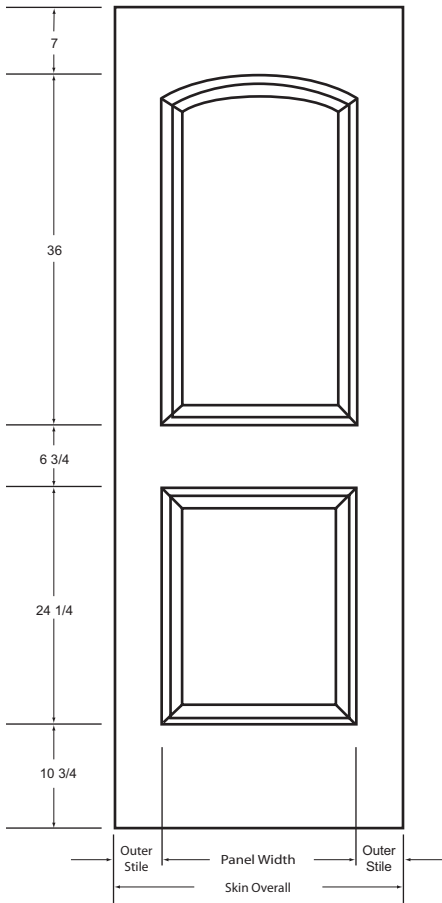

HOLLOW CORE CONSTRUCTION

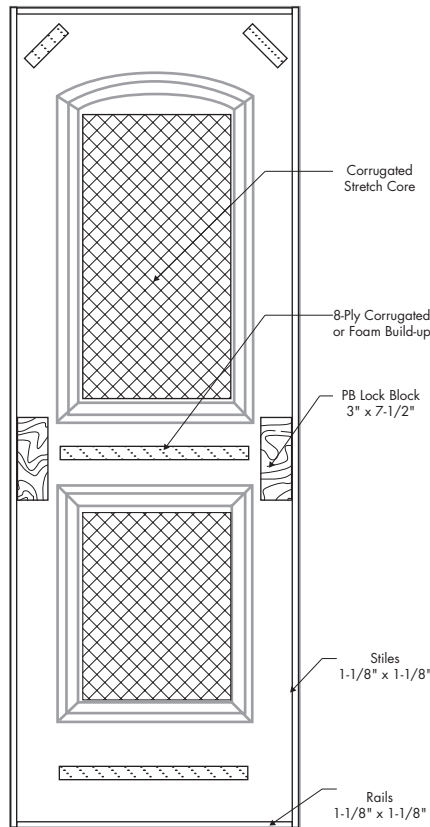

SOLID CORE CONSTRUCTION

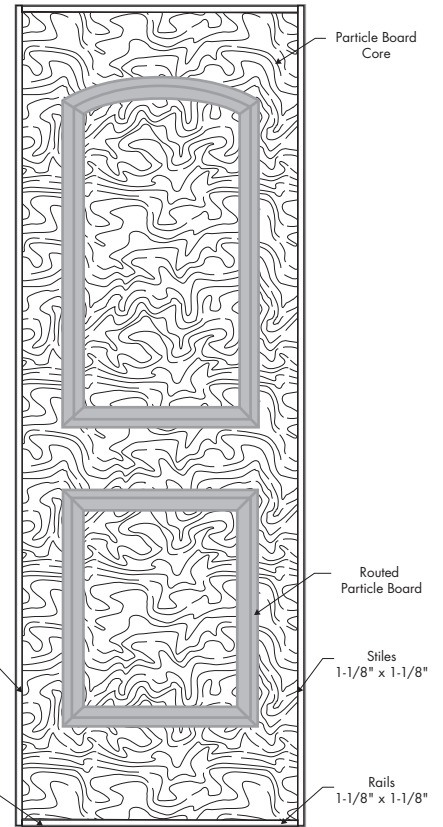

*Measurements are approximate and before any required trim or adjustments for customer specifications

Smooth skin faces are paint grade only.
All measurements are approximate.
All door facings are nominal 1/8" thick.
Type 2 glue bond standard.

Skin Size	Skin Overall	Panel Width	Center Stile	Outer Stile	Skin Size	Skin Overall	Panel Width	Center Stile	Outer Stile
1'0" x 7'0"	1'0-3/8"	7-1/16"	NA	2-21/32"	2'2" x 7'0"	2'2-3/8"	1'3-11/16"	NA	5-11/32"
1'2" x 7'0"	1'2-3/8"	7-1/16"	NA	3-21/32"	2'4" x 7'0"	2'4-3/8"	1'5-11/16"	NA	5-11/32"
1'3" x 7'0"	1'3-3/8"	7-1/16"	NA	4-5/32"	2'6" x 7'0"	2'6-3/8"	1'7-11/16"	NA	5-11/32"
1'4" x 7'0"	1'4-3/8"	7-1/16"	NA	4-21/32"	2'8" x 7'0"	2'8-3/8"	1'9-11/16"	NA	5-11/32"
1'6" x 7'0"	1'6-3/8"	11-15/16"	NA	3-7/32"	2'10" x 7'0"	2'10-3/8"	1'9-11/16"	NA	6-11/32"
1'8" x 7'0"	1'8-3/8"	11-15/16"	NA	4-7/32"	3'0" x 7'0"	3'0-3/8"	1'11-11/16"	NA	6-11/32"
2'0" x 7'0"	2'0-3/8"	1'3-11/16"	NA	4-11/32"					

Note: A standard 2-1/8" bore diameter will require a minimum stile measurement of 3-11/16" to allow for a 2-3/8" backset. A standard 2-1/8" bore diameter will require a minimum stile measurement of 4-1/16" to allow for a 2-3/4" backset.